

普通寸法差 (前加工)			
呼び寸法ノ区分	公差	公差	公差
H7/k6	H7/f7	H7/g6	H7/g5
H8/k7	H8/f8	H8/g7	H8/g6
H9/k8	H9/f9	H9/g8	H9/g7
H10/k9	H10/f10	H10/g9	H10/g8
H11/k10	H11/f11	H11/g10	H11/g9
H12/k11	H12/f12	H12/g11	H12/g10
H13/k12	H13/f13	H13/g12	H13/g11
H14/k13	H14/f14	H14/g13	H14/g12
H15/k14	H15/f15	H15/g14	H15/g13
H16/k15	H16/f16	H16/g15	H16/g14
H17/k16	H17/f17	H17/g16	H17/g15
H18/k17	H18/f18	H18/g17	H18/g16
H19/k18	H19/f19	H19/g18	H19/g17
H20/k19	H20/f20	H20/g19	H20/g18
H21/k20	H21/f21	H21/g20	H21/g19
H22/k21	H22/f22	H22/g21	H22/g20
H23/k22	H23/f23	H23/g22	H23/g21
H24/k23	H24/f24	H24/g23	H24/g22
H25/k24	H25/f25	H25/g24	H25/g23
H26/k25	H26/f26	H26/g25	H26/g24
H27/k26	H27/f27	H27/g26	H27/g25
H28/k27	H28/f28	H28/g27	H28/g26
H29/k28	H29/f29	H29/g28	H29/g27
H30/k29	H30/f30	H30/g29	H30/g28
H31/k30	H31/f31	H31/g30	H31/g29
H32/k31	H32/f32	H32/g31	H32/g30
H33/k32	H33/f33	H33/g32	H33/g31
H34/k33	H34/f34	H34/g33	H34/g32
H35/k34	H35/f35	H35/g34	H35/g33
H36/k35	H36/f36	H36/g35	H36/g34
H37/k36	H37/f37	H37/g36	H37/g35
H38/k37	H38/f38	H38/g37	H38/g36
H39/k38	H39/f39	H39/g38	H39/g37
H40/k39	H40/f40	H40/g39	H40/g38
H41/k40	H41/f41	H41/g40	H41/g39
H42/k41	H42/f42	H42/g41	H42/g40
H43/k42	H43/f43	H43/g42	H43/g41
H44/k43	H44/f44	H44/g43	H44/g42
H45/k44	H45/f45	H45/g44	H45/g43
H46/k45	H46/f46	H46/g45	H46/g44
H47/k46	H47/f47	H47/g46	H47/g45
H48/k47	H48/f48	H48/g47	H48/g46
H49/k48	H49/f49	H49/g48	H49/g47
H50/k49	H50/f50	H50/g49	H50/g48
H51/k50	H51/f51	H51/g50	H51/g49
H52/k51	H52/f52	H52/g51	H52/g50
H53/k52	H53/f53	H53/g52	H53/g51
H54/k53	H54/f54	H54/g53	H54/g52
H55/k54	H55/f55	H55/g54	H55/g53
H56/k55	H56/f56	H56/g55	H56/g54
H57/k56	H57/f57	H57/g56	H57/g55
H58/k57	H58/f58	H58/g57	H58/g56
H59/k58	H59/f59	H59/g58	H59/g57
H60/k59	H60/f60	H60/g59	H60/g58
H61/k60	H61/f61	H61/g60	H61/g59
H62/k61	H62/f62	H62/g61	H62/g60
H63/k62	H63/f63	H63/g62	H63/g61
H64/k63	H64/f64	H64/g63	H64/g62
H65/k64	H65/f65	H65/g64	H65/g63
H66/k65	H66/f66	H66/g65	H66/g64
H67/k66	H67/f67	H67/g66	H67/g65
H68/k67	H68/f68	H68/g67	H68/g66
H69/k68	H69/f69	H69/g68	H69/g67
H70/k69	H70/f70	H70/g69	H70/g68
H71/k70	H71/f71	H71/g70	H71/g69
H72/k71	H72/f72	H72/g71	H72/g70
H73/k72	H73/f73	H73/g72	H73/g71
H74/k73	H74/f74	H74/g73	H74/g72
H75/k74	H75/f75	H75/g74	H75/g73
H76/k75	H76/f76	H76/g75	H76/g74
H77/k76	H77/f77	H77/g76	H77/g75
H78/k77	H78/f78	H78/g77	H78/g76
H79/k78	H79/f79	H79/g78	H79/g77
H80/k79	H80/f80	H80/g79	H80/g78
H81/k80	H81/f81	H81/g80	H81/g79
H82/k81	H82/f82	H82/g81	H82/g80
H83/k82	H83/f83	H83/g82	H83/g81
H84/k83	H84/f84	H84/g83	H84/g82
H85/k84	H85/f85	H85/g84	H85/g83
H86/k85	H86/f86	H86/g85	H86/g84
H87/k86	H87/f87	H87/g86	H87/g85
H88/k87	H88/f88	H88/g87	H88/g86
H89/k88	H89/f89	H89/g88	H89/g87
H90/k89	H90/f90	H90/g89	H90/g88
H91/k90	H91/f91	H91/g90	H91/g89
H92/k91	H92/f92	H92/g91	H92/g90
H93/k92	H93/f93	H93/g92	H93/g91
H94/k93	H94/f94	H94/g93	H94/g92
H95/k94	H95/f95	H95/g94	H95/g93
H96/k95	H96/f96	H96/g95	H96/g94
H97/k96	H97/f97	H97/g96	H97/g95
H98/k97	H98/f98	H98/g97	H98/g96
H99/k98	H99/f99	H99/g98	H99/g97
H100/k99	H100/f100	H100/g99	H100/g98

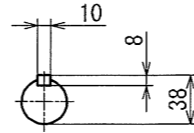

主要諸元
 4500rpm時最大トルク380Nm
 : 180KW相当
 最大入力回転数: 8000rpm
 出力回転数: 16000rpm
 増速比: 2/1

入出力軸シールは非接触ラビリンス方式
 潤滑は強制潤滑方式

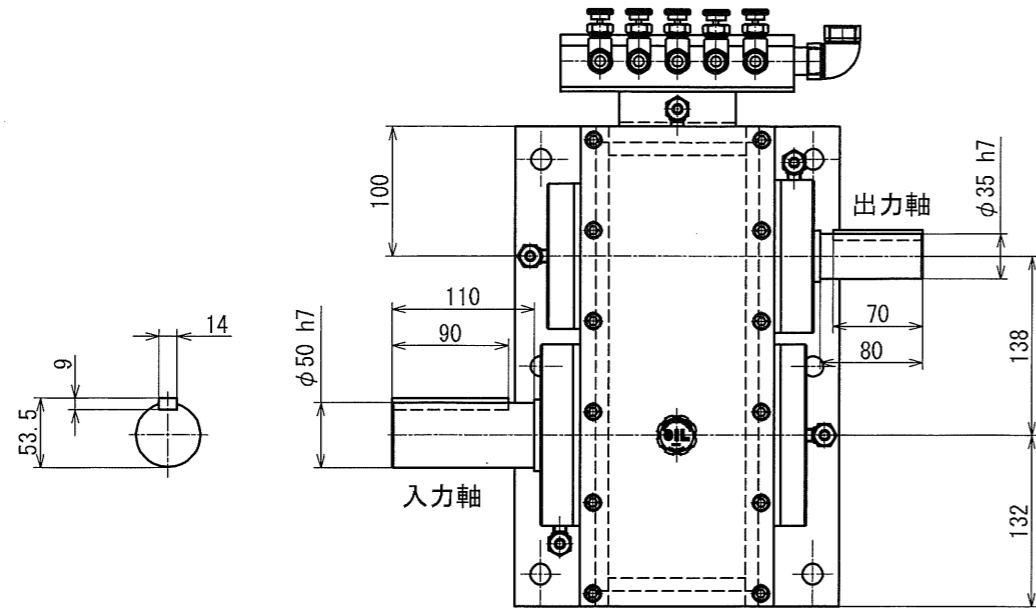
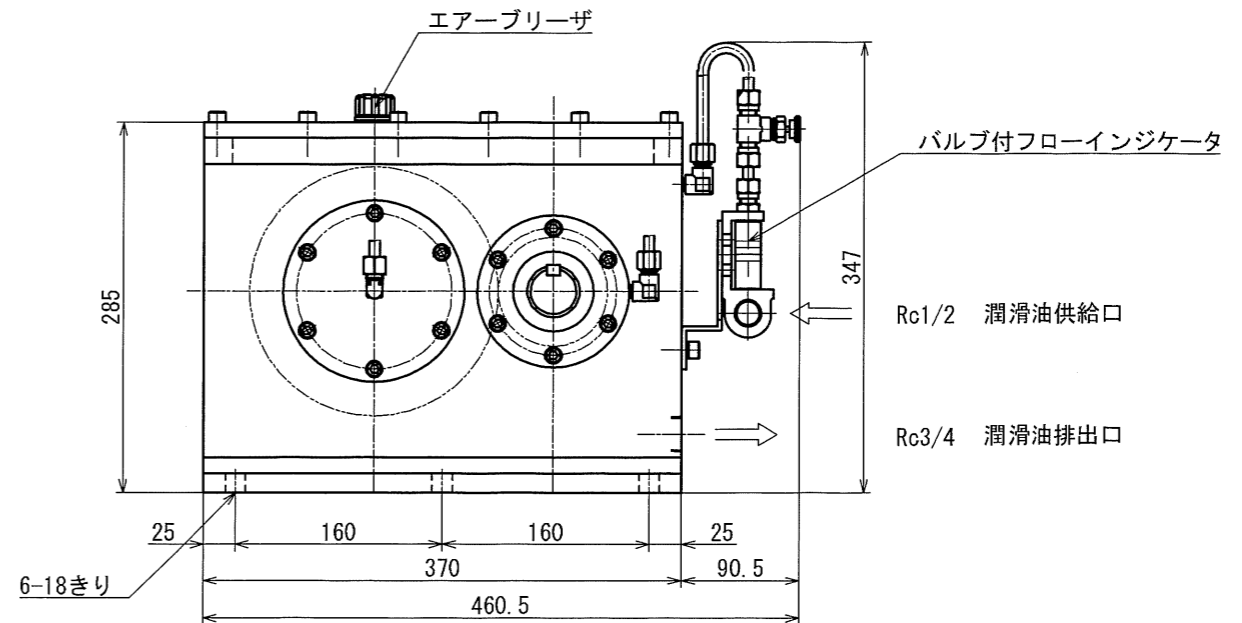
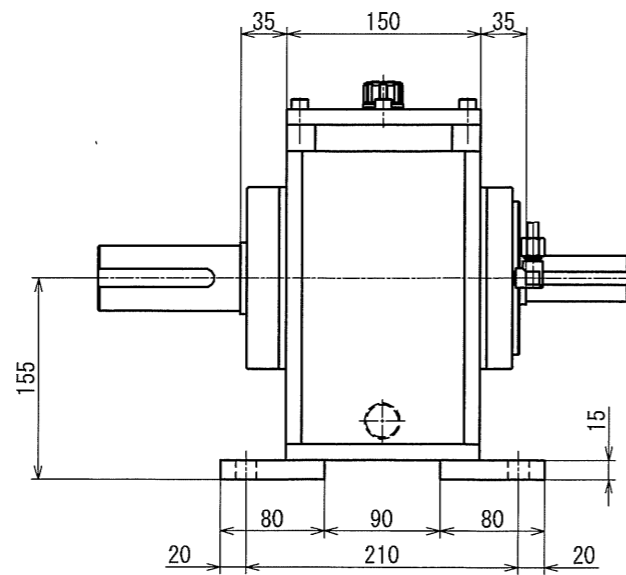

図番	MS-180-2HA-0D	図面名称	概略寸法図			
形式名称	MS-180-2HA 型変速機	尺度	1:4	角法	⊙ ⊚	
株式会社 益製作所	日付	2022年1月25日	承認	検図	製図	⊙